

Product Overview

AX-AFS-2 is a electro-mechanical flow switch for use in ventilation systems. The AX-AFS-2 flow switch is intended for flow control of air and non-aggressive gas. They have a built-in switch with an alarm signal for flow shortage signalling.

Applications AX-AFS-2 is well-suited for ducts used in general industrial applications, such as:

- Air conditioning systems
- Ventilation ducts
- Air treatment facilities

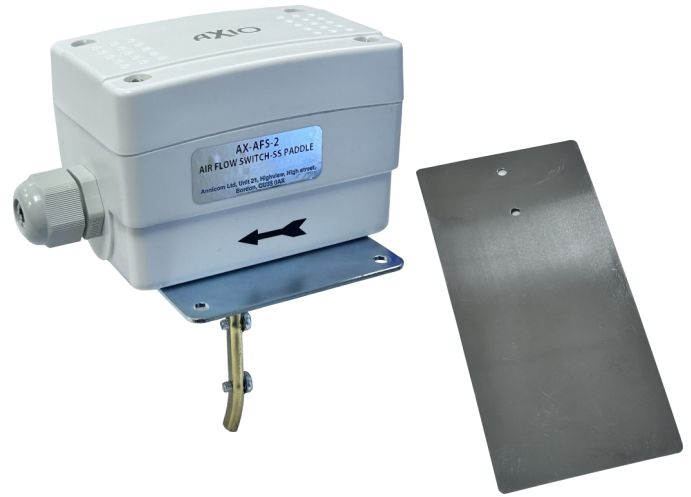

Products Features

- Paddle can be trimmed to fit higher air flows
- For vertical or horizontal mounting
- IP54 Housing
- Breaking capacity 15 (8) A at 24...250 VAC
- Protection class IP54
- Brass level

Product Specifications

Contact:	Dust-tight microswitch with switching contacts NO/NC
Switch capacity:	SPDT, 24/250 VAC, 15 (8) A
Flow rate switching:	(Cut-out) Min. 1.0 m/sec, Max. 8.0 m/sec (Cut-in) Min. 2.5 m/sec, Max. 9.2 m/sec
Paddle size:	3.2 x 6.9 in. (80 x 175 mm)
Paddle w/level - Length	7.9 in. (200 mm)
Material	(Paddle) Galvanized Steel (Level) Brass (Enclosure) Fire retardant ABS plastic
Operating temperature:	(Housing) -40°C to 85°C (Paddle) -10°C to 85°C
Humidity:	10 - 90% RH, non-condensing
Cable entry:	M18 fitting
Protection:	IP54
Compliances:	CE
Country of origin :	China

Product Order Codes

Order Code	Min. air flow (m/s)	Max. air flow (m/s)	Max. air temp (°C)
AX-AFS-2	1.0 (not trimmed) or 2.5 (trimmed)	8.0 (not trimmed) or 9.2 (trimmed)	85

Installation

The flow switch should be mounted into a duct or chamber where the air paddle can freely point horizontally downwards. To avoid air swirl and paddle instability, straight zones should be provided for a length of 5 times the diameter of duct upstream and downstream from the installation location.

Note:
The units are factory calibrated to the minimum switch-off value. To increase the set value, adjust the range screw clockwise. Due to the risk of fracture at air speeds of higher than 5.0 m/sec, the paddle must be cut off on the marked side. When the paddle is cut off, the minimum cut-out value increases from 1.0 m/sec to 2.5 m/sec.

Dimensions

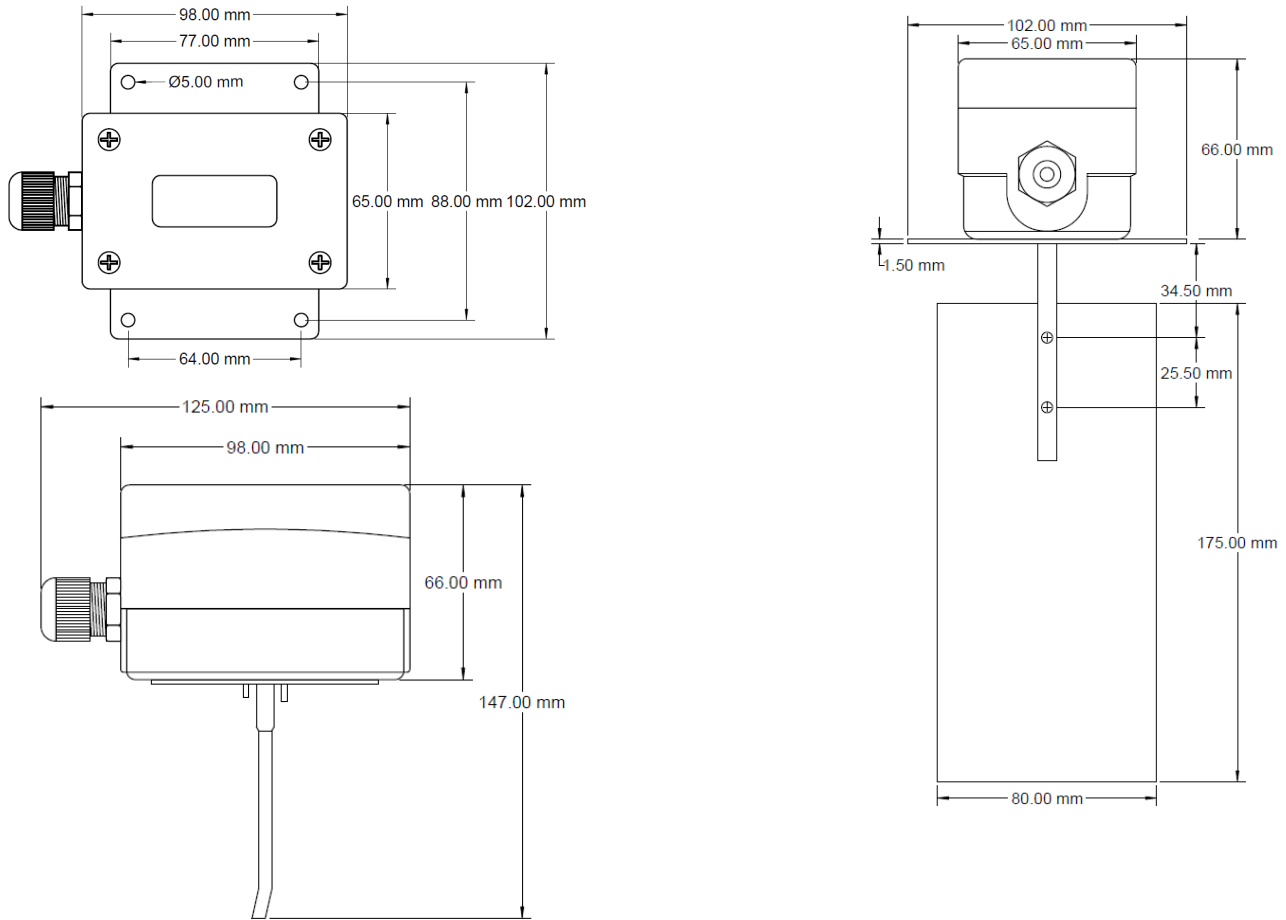

Electrical Connection

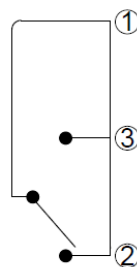
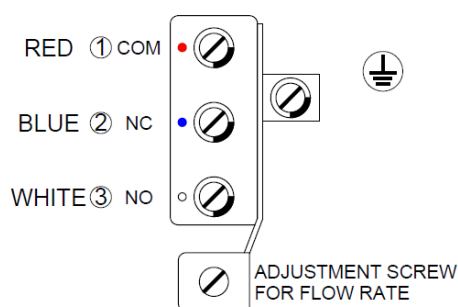

Flow increase and attained to cut-in setting
1 and 2 connected

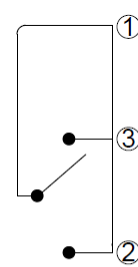

Flow decrease and attained to cut-out setting
1 and 3 connected

Datasheet Contents

Every effort has been taken in the production of this data sheet to ensure accuracy. Annicom do not accept responsibility for any damage, expense, injury, loss or consequential loss resulting from any errors or omissions. Annicom has a policy of continuous improvement and reserves the right to change this specification without notice.