

Product Overview

The Axio AX-RM6M converts a 0-10Vdc or 2-10Vdc control signal into a 6 relay output with 9 selectable modes: Stage, Sequence, Raise/Lower, Binary, Circular, Power-on stage and Power-on sequence including an cascaded option to work with an AX-RM4M to form a 10 stage unit, switching in 1 volt steps. In certain modes the output sequence can be reversed. The module is powered by 24Vac or 24Vdc and Auto/Hand/Off jumpers are provided to aid commissioning, with individual LEDs to indicate the relay states. The AX-RM6M is supplied in a DIN rail carrier for mounting on TS35 section DIN rail and features high quality rising clamp terminals for ease of connection.

Features

- 0-10 or 2-10 volt input
- 6 SPCO relays
- Step and reverse options
- Adjustable reaction time
- Cascade with AX-RM4M for 10 stages
- Binary output
- DIN rail carrier as standard (TS35 DIN rail)
- High quality rising clamp terminals

Product Specifications

Input Signals	Control 0-10Vdc or 2-10Vdc at 1mA maximum
	Reverse Volt free contact to switch 0.5mA
Output Contacts	6 SPCO relays. NO contact 12A, NC contact 3A, 250Vac resistive load
Power Supply	24Vac $\pm 10\%$ at 140mA maximum
	24Vdc $\pm 10\%$ at 100mA maximum
Modes of Operation	9 modes, see Mode table
Manual Override	Auto / Hand (On) / Off
LED Indicators	On when relay energised
Time Delay	0-60 seconds
Settling Time	0.1 or 1 seconds
Step Mode	Sequence through intermediate steps
Terminals	Rising clamp for 0.5-2.5mm ² cable
Ambient Temperature Range	0°C to 50°C
Dimensions / Weight	114(W) x 82(H) x 44(D)mm / 185gms
Country of Origin	United Kingdom

Order Codes

AX-RM6M Six Stage, Multi Mode, Relay Output Module

Installation

The AX-RM6M should be installed by suitably qualified technician in conjunction with any guidelines for the equipment it is to be connected to and any local regulations. Field wiring should be installed to satisfy the requirements set out by the manufacturer of the equipment that the module is being connected to.

Description, tables and connections

Mode	Mode 1	Mode 2	Reverse	Step	Description	Table
Stage	C	C	Select	Select	Outputs accumulate as input increases	1
Sequence	C	B	Select	Select	Single output switches on as input increases	1
Raise/Lower	B	A	Select	Select	Similar to stage mode, but centred at 5V input	1
Binary	B	B	Off	Off	Outputs switch in binary sequence as input increases	5
Circular	A	C	Off	On	Outputs switch on/off in a circular order (duty sharing)	2
Powered on Staged	A	B	Off	On	Outputs accumulate from when power is applied	1
Power on Sequence	B	C	Off	On	Single outputs switch on from when power is applied	1
Cascaded Stage	C	A	Off	Off	Used with an AX-RM4M to create a 10 stage mode	3
Cascaded Sequence	A	A	Off	Off	Used with an AX-RM4M to create 10 sequence stage	3

Modes

The mode table shows the available modes with the MODE1 and MODE2 jumper selection. The Reverse and Step options can only be selected in the modes shown on the table. The Power on modes do not require the control signal input, and are intended for soft start of loads with up to 6 circuits.

Output

The output tables show the switching actions provided by the different modes. These are referred to the input voltages. The circular and binary mode outputs are shown on separate tables. The relay off state is shown by a small dash.

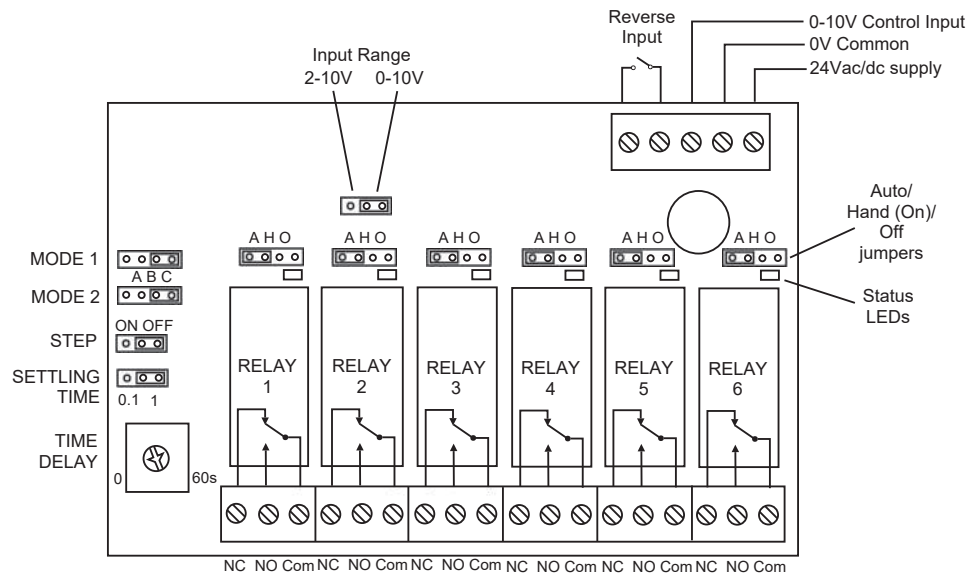

Table 1		Stage						Sequence						Raise/Lower					
Input		Relay						Relay						Relay					
0-10	2-10	1	2	3	4	5	6	1	2	3	4	5	6	1	2	3	4	5	6
0	2.0	-	-	-	-	-	-	-	-	-	-	-	-	On	On	On	-	-	-
2.0	3.60	On	-	-	-	-	-	On	-	-	-	-	-	-	On	On	-	-	-
3.0	4.40	On	On	-	-	-	-	-	On	-	-	-	-	-	-	On	-	-	-
4.5	5.60	On	On	On	-	-	-	-	-	On	-	-	-	-	-	-	-	-	-
6.0	6.80	On	On	On	On	-	-	-	-	-	On	-	-	-	-	-	On	-	-
7.8	8.24	On	On	On	On	On	-	-	-	-	-	On	-	-	-	-	On	On	-
10.0	10	On	On	On	On	On	On	-	-	-	-	-	On	-	-	-	On	On	On

Stage jumper (On / Off)

When Step is set to Off, the outputs change directly to the demanded. When Step is set to On the outputs step through all intermediate stages with timing set by the stage delay timer.

Settling Time (0.1 / 1 second)

This sets the time input has to remain within limits before being actioned. For slowly changing inputs this should be placed in the 1 second position.

Input Range (0-10 / 2-10 Volts)

Select the input range between 0-10 and 2-10 Volts.

Time Delay (0 to 60 seconds)

Provides an adjustable time delay between stages switching on and off. Also provides the delay start time setting for the two Power on modes.

Reverse Input

When not connected, the outputs follow the sequence in the tables. When terminals are connected together, the outputs follow a reverse sequence (only available in Stage, Sequence and Raise Lower modes).

Guaranteed Input Voltage

The guaranteed input operating switching ranges are shown in Table 4. Voltages outside these limits will operate as normal but no guarantee is given on the exact switching points. The standard switching points used within the BMS industry fall within these ranges.

Table 2			Circular					
Input		Dmd	Relay					
0-10	2-10		1	2	3	4	5	6
0	2.0	0	-	-	-	-	-	-
2	3.6	1	On	-	-	-	-	-
3	4.2	2	On	On	-	-	-	-
4.5	5.4	3	On	On	On	-	-	-
3	4.2	2	-	On	On	-	-	-
2	3.6	1	-	-	On	-	-	-
3	4.2	2	-	-	On	On	-	-
4.5	5.4	3	-	-	On	On	On	-
3	4.2	2	-	-	-	On	On	-
2	3.6	1	-	-	-	-	On	-
3	4.2	2	-	-	-	-	On	On
4.5	5.4	3	On	-	-	-	On	On
6	6.6	4	On	On	-	-	On	On
4.5	5.4	3	On	On	-	-	-	On
3	4.2	2	On	On	-	-	-	-
2	3.6	1	-	On	-	-	-	-
0	2.0	0	-	-	-	-	-	-

Table 3		Cascaded Stage						Cascaded Sequence					
Input		Relay						Relay					
0-10	2-10	1	2	3	4	5	6	1	2	3	4	5	6
0-4	2-5.2	-	-	-	-	-	-	-	-	-	-	-	-
5.0	6.0	On	-	-	-	-	-	On	-	-	-	-	-
6.0	6.8	On	On	-	-	-	-	-	On	-	-	-	-
7.0	7.6	On	On	On	-	-	-	-	-	On	-	-	-
8.0	8.4	On	On	On	On	-	-	-	-	-	On	-	-
9.0	9.2	On	On	On	On	On	-	-	-	-	-	On	-
10	10	On	On	On	On	On	On	-	-	-	-	-	On

Table 4		Switching voltages	
Mode	Not Binary	Binary	
0-10V	±0.4V	±0.025V	
2-10V	±0.3V	±0.020V	

Table 5A		Binary					
Input		Relay					
0-10	2-10	1	2	3	4	5	6
0.000	2.000	-	-	-	-	-	-
0.156	2.125	On	-	-	-	-	-
0.313	2.250	-	On	-	-	-	-
0.469	2.375	On	On	-	-	-	-
0.625	2.501	-	-	On	-	-	-
0.781	2.626	On	-	On	-	-	-
0.938	2.751	-	On	On	-	-	-
1.094	2.876	On	On	On	-	-	-
1.250	3.001	-	-	-	On	-	-
1.406	3.126	On	-	-	On	-	-
1.563	3.251	-	On	-	On	-	-
1.719	3.376	On	On	-	On	-	-
1.875	3.502	-	-	On	On	-	-
2.031	3.627	On	-	On	On	-	-
2.188	3.752	-	On	On	On	-	-
2.344	3.877	On	On	On	On	-	-
2.500	4.002	-	-	-	-	On	-
2.656	4.127	On	-	-	-	On	-
2.813	4.252	-	On	-	-	On	-
2.969	4.377	On	On	-	-	On	-
3.125	4.503	-	-	On	-	On	-
3.281	4.628	On	-	On	-	On	-
3.438	4.753	-	On	On	-	On	-
3.594	4.878	On	On	On	-	On	-
3.750	5.003	-	-	-	On	On	-
3.906	5.128	On	-	-	On	On	-
4.063	5.253	-	On	-	On	On	-
4.219	5.378	On	On	-	On	On	-
4.375	5.504	-	-	On	On	On	-
4.531	5.629	On	-	On	On	On	-
4.688	5.754	-	On	On	On	On	-
4.844	5.879	On	On	On	On	On	-

Binary input voltage calculations

Step input (0-10V)

$$(9.844 / 63) \times \text{Step Volts}$$

Table 5A		Binary					
Input		Relay					
0-10	2-10	1	2	3	4	5	6
5.000	6.004	-	-	-	-	-	On
5.156	6.129	On	-	-	-	-	On
5.313	6.254	-	On	-	-	-	On
5.469	6.379	On	On	-	-	-	On
5.625	6.505	-	-	On	-	-	On
5.781	6.630	On	-	On	-	-	On
5.938	6.755	-	On	On	-	-	On
6.094	6.880	On	On	On	-	-	On
6.250	7.005	-	-	-	On	-	On
6.406	7.130	On	-	-	On	-	On
6.563	7.255	-	On	-	On	-	On
6.719	7.380	On	On	-	On	-	On
6.875	7.506	-	-	On	On	-	On
7.031	7.631	On	-	On	On	-	On
7.188	7.756	-	On	On	On	-	On
7.344	7.881	On	On	On	On	-	On
7.500	8.006	-	-	-	-	On	On
7.656	8.131	On	-	-	-	On	On
7.813	8.256	-	On	-	-	On	On
7.969	8.381	On	On	-	-	On	On
8.125	8.507	-	-	On	-	On	On
8.281	8.632	On	-	On	-	On	On
8.438	8.757	-	On	On	-	On	On
8.594	8.882	On	On	On	-	On	On
8.750	9.007	-	-	-	On	On	On
8.906	9.132	On	-	-	On	On	On
9.063	9.257	-	On	-	On	On	On
9.219	9.382	On	On	-	On	On	On
9.375	9.508	-	-	On	On	On	On
9.531	9.633	On	-	On	On	On	On
9.688	9.758	-	On	On	On	On	On
9.844	9.883	On	On	On	On	On	On

Binary input voltage calculations

Step input (2-10V)

$$[(7.883 / 63) \times \text{Step}] + 2.0 \text{ Volts}$$

Every effort has been taken in the production of this data sheet to ensure accuracy. Axio do not accept responsibility for any damage, expense, injury, loss or consequential loss resulting from any errors or omissions. Axio has a policy of continuous improvement and reserves the right to change this specification without notice.