

Product Guide

Standard Humidistat with LED indicators

today, tomorrow and in the future

mselectronics.co.uk

Product Overview

The E923 humidistat offers a calibration-free, high accuracy and high quality solution to humidity control in an electrical accessory plate form factor.

The E923 regulates to a fully adjustable relative humidity setpoint between 5% and 95%, combined with an adjustable relative humidity hysteresis (differential) of anything between 1% and 10%.

3 LED indicators on the front of the unit illustrate the currently detected relative humidity level in relation to the desired setpoint. The green indicator is illuminated when the sensed humidity is within the selected differential band around the setpoint. The appropriate red indicator illuminates to indicate that the sensed humidity is detected as above or below the differential band around the setpoint.

Product Wiring

- IMPORTANT:** ensure all electrical connections are isolated before commencing any work on the unit.
- Power to the humidistat is provided via the Live and Neutral input terminals labelled “L” and “N” (230V AC, 50Hz). On the 24 volt product variant (“/24V”) the same terminals are used (24V AC or DC) and are not polarity sensitive.
- A voltage-free changeover relay output capable of switching loads of up to 10A, 250V AC (resistive) is provided by the humidistat. Connect to your application in an appropriate manner given the following:
 - The Common “COM” terminal is connected to the Normally Open “NO” terminal when the relative humidity is sensed to be above the “Setpoint” humidity (use to control dehumidifiers).
 - Conversely, the “COM” terminal is connected to the Normally Closed “NC” terminal when the relative humidity is sensed to be below the “Setpoint” humidity (use to control humidifiers).

Figure 1 Typical wiring example

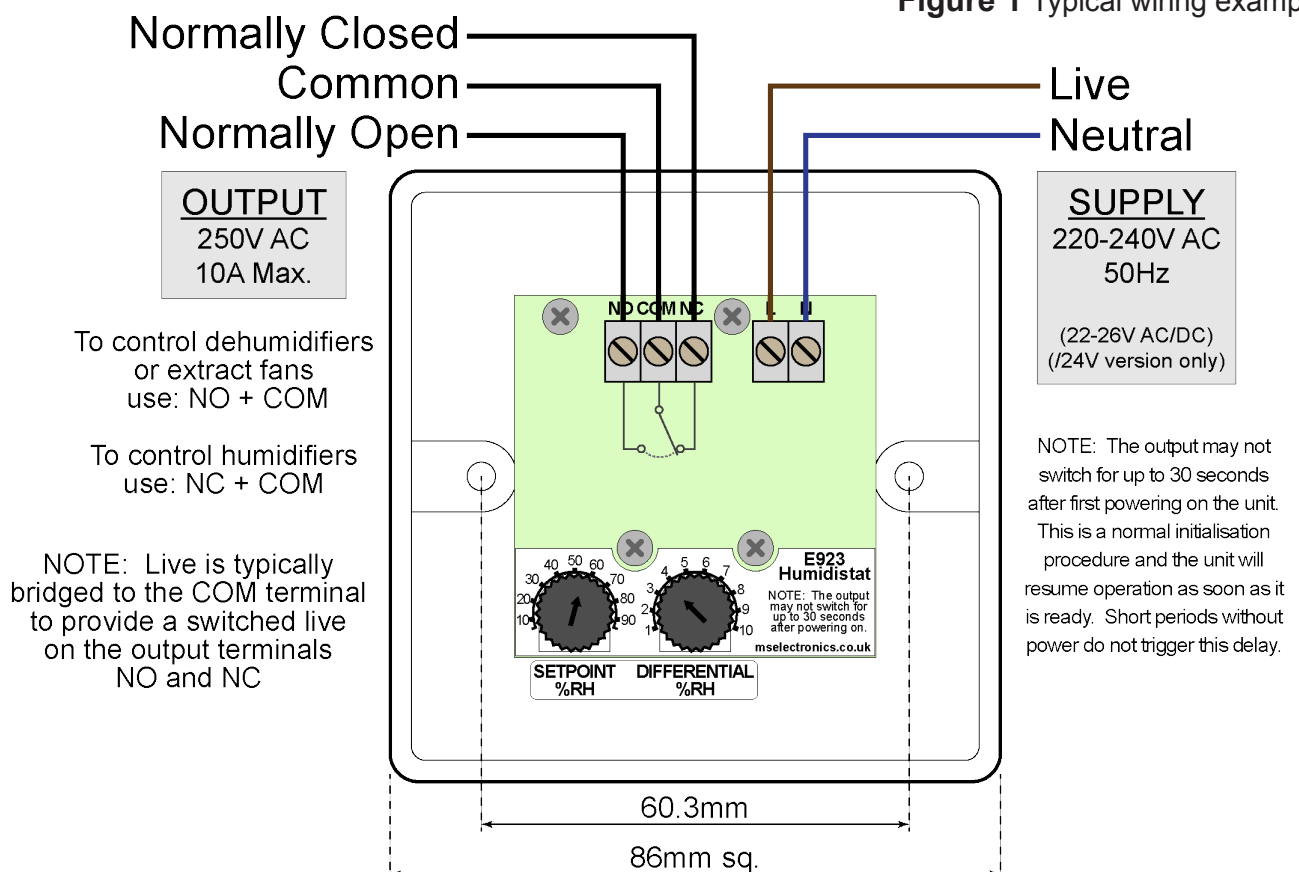

Installation

1. **IMPORTANT:** ensure all electrical connections are isolated before commencing any work on the unit.
2. The E923 is designed to be mounted in a 20mm (or deeper) single-gang UK pattress box.
3. Connect the wiring to the terminal blocks on the humidistat as shown in Figure 1 (or any suitably appropriate form). Make sure to choose the correct output terminals that are suitable to your application.
4. Adjust the internal controls to suit the installation operational requirements (see below).
5. Secure the E923 into the pattress box using the two supplied M3.5 screws.

Operation

1. **IMPORTANT:** ensure all electrical connections are isolated before commencing any work on the unit.
2. Adjust the “Setpoint” dial to the relative humidity the room is to be regulated to.
3. Set the “Differential” to the total relative humidity swing either side of the “Setpoint” that the room humidity is required to keep within.
4. Example of a typical set-up:
 - Setpoint set to 70% RH, Differential set to 4% RH.
 - The unit will maintain the relative humidity between 68% RH and 72% RH (Green LED is lit).
 - The corresponding Red LED will light if the sensed RH falls below 68% or above 72%.

Notes

1. **Applying power for the first time:** The output of the humidistat may not switch in response to humidity for up to 30 seconds after first powering on. This is normal behaviour due to a necessary initialisation phase - please wait until this is completed before attempting to test the humidistat. Both red LEDs will flash to indicate that initialisation is in progress. Normal operation will resume as soon as the initialisation phase has completed.
If the unit has already completed initialisation then short interruptions of power of up to 5 minutes or more will not trigger the initialisation phase and the humidistat will resume normal operation immediately within a couple of seconds. Power interruptions longer than 5 minutes may trigger the initialisation phase again.

Technical Specification	
Power supply:	220V - 240V AC 50Hz (live/neutral) “/24V” variant: 22V - 26V AC or DC
Output switch rating:	10A, 250V AC 50Hz (resistive)
Output switch type:	Changeover relay (volt-free)
Humidity control:	5% RH to 95% RH
Humidity differential:	1% RH to 10% RH
Sensor accuracy:	+/- 3% RH
Sensor drift:	+/- 1.2% RH over 5 years (no calibration required)
Guarantee:	3 Years
Weight:	97g
Dimensions:	86mm x 86mm x 26.9mm

Technical Support

For further help or information on this and the other products in the MS Electronics range visit www.mselectronics.co.uk or call 0333 666 1176.

Alternatively, email techsupport@mselectronics.co.uk
Additional copies of this product guide can be downloaded from our website.

Product Warranty

MS Electronics guarantees all their products against manufacturing defects for 5 years from the purchase date. If your product is found to be faulty, MS Electronics will, at their discretion, repair or replace the product free of charge.

Note

Any modification or damage to the outer casing of the product, as well as any damage to the product due to abuse or incorrect wiring may invalidate the guarantee.



e: info@mselectronics.co.uk
t: 0333 666 1176 f: 0333 666 1436



mselectronics.co.uk

Follow us on twitter: [@mselec](https://twitter.com/mselec)

MS Electronics reserves the right to alter or change this specification without prior notice.